



DETERMINANTS OF FARMERS' INTENTION OF APPLYING NEW TECHNOLOGY IN PRODUCTION: THE CASE OF VIETGAP STANDARD ADOPTION IN VIETNAM

Luong Tinh ^{† a}, ^a [†] Institute of Social Sciences of Central Region, Vietnam
Academy of Social Sciences, Vietnam
Phan Tran Minh Hung ^b, ^b University of Economics- Da Nang University, Vietnam
Doan Gia Dzung ^c, ^c Duy Tan University, Vietnam
Vo Hoang Diem Trinh ^b [†] ✉ luonghatinh@gmail.com (Corresponding author)



Corresponding author

ARTICLE HISTORY:

Received: 13-Jun-2019

Accepted: 21-Aug-2019

Online Available: 10-Sep-2019

Keywords:

VietGAP,
Farmers,
Vegetable production,
Technological application

ABSTRACT

The purpose of this paper is to identify the determinants of farmers' intention of applying new technology with the case of VietGAP standard application in vegetable production in a developing country such as Vietnam. Using the survey data of agricultural workers in a framework of revised technology acceptance model, the analysis finds that farmers' intention to apply or continue applying VietGAP is driven by factors such as mutual communication, awareness of benefits, environment, behavioral control, and governmental support based on authorities' policies and risk awareness. Unlike other studies, this paper illustrates that awareness of the brand name related risk and producers' health benefits have statistically significant impacts on farmers' intentions.

Contribution/ Originality

The key novelty of this study is to identify the determinants of the intention of VietGAP acceptance in the case of Vietnam in general and those of Quangnam and Danang in particular. The determinants of the intention of VietGAP adoption stem from motivational, psychological, and perceptive factors.

DOI: [10.18488/journal.1005/2019.9.2/1005.2.164.178](https://doi.org/10.18488/journal.1005/2019.9.2/1005.2.164.178)

ISSN (P): 2304-1455/ISSN (E):2224-4433



How to cite: Luong Tinh, Phan Tran Minh Hung, Doan Gia Dzung and Vo Hoang Diem Trinh (2019). Determinants of farmers' intention of applying new technology in production: The case of VietGAP standard adoption in Vietnam. Asian Journal of Agriculture and Rural Development, 9(2), 164-178.

© 2019 Asian Economic and Social Society. All rights reserved.

1. INTRODUCTION

A growing body of literature has highlighted important roles of adoption of technological innovation in the agricultural sector. The implementation of technological innovation in the agricultural sector has had the attention of many scholars from different fields since [Bernoulli's \(1954\)](#) utility theory on the comparison of the benefits and risks of farmers when deciding to apply innovation. Subsequently, the approach from the psychological and behavioral perspectives of households such as the diffusion of innovations ([Rogers, 1962](#)) and the planned behavior theory ([Ajzen, 1991](#)) appeared to establish a comprehensively theoretical framework on the technological application in the agrarian sector.

Existing empirical evidence also demonstrates the probability of applying these theories in reality. Nevertheless, no high consensus is documented in the determinants of adoption of technological innovation. Approaches to psychological perspectives reveal that attitudes, social norms, and behavioral awareness are the most important determinants of the intention of acceptance of technological innovation ([Borges et al., 2014](#); [Wauters and Mathijs, 2013](#)). Making decisions is also dominated by farmers' perception of the benefits and risks of innovation (according to the utility theory), hence economic risks play an essential role ([Ghadim et al., 2005](#)). The implementation of technological innovation in the agricultural sector is not impacted just by psychological characteristics, but also by economic conditions, social, and cultural factors. [Lynne et al. \(1995\)](#) and [Bergevoet et al. \(2004\)](#) document that economic conditions are not enough to account for complicated decisions typically driven by the combination of economic and other factors. Almost all theoretical frameworks and empirical evidence incline toward explaining the behavior of the application of technological innovation through a particular industry's perspective ([Pannell et al., 2006](#)).

On one hand green vegetables are considered to be one of the most vital components in family meals. Their role is even more important when individuals are increasingly inclined to follow a very strict diet in Vietnam. On the other hand the supply of safe vegetables has confronted immensely huge challenges. Therefore VietGap, the ASEANGAP including rules, methods, and processes of agricultural practices valuable for vegetables and fruit in Vietnam have had novel contributions to the safe vegetable industry in Vietnam. Although VietGAP has just been implemented in places such as Thuathienhue, Bacgiang, and Hanoi, it has brought highly economic efficiency ([Hoang, 2018](#); [Vu et al., 2016](#)). However, the production of green vegetables under VietGAP standards has not been expanded in recent years because of supply and demand restrictions. Effects on supply include farmers' limited awareness of the benefits of VietGAP products ([Vu et al., 2016](#)); lack of production capital; dispersed and fragmented production land ([Mensah et al., 2017](#); [Hoang, 2018](#)). Shortage of planning and orienting of local authorities to form specialized production areas of green vegetables on a large scale represents one of the main reasons for these restrictions ([Vu et al., 2016](#); [Hoang, 2018](#)). Restrictions on demand contain shortage of market demand for VietGAP certified vegetables, risks related to breaking informal institutions between farmers and preferred collectors, and lack of capability in the key value chain ([Hoang, 2018](#)). The restrictions and success of VietGAP have sparked substantial interest in the determinants of the application of the technological innovation. Therefore mixed theoretical predictions and at least partly ambiguous empirical findings motivate us to revisit the question of whether the adoption of technological innovation will be driven by which factors in the case of VietGAP in the context of an agricultural country like Vietnam.

To the best of our knowledge we are the first to comprehensively examine the determinants of the intention of VietGAP adoption in Vietnam in general and in Quangnam and Danang in particular. Therefore the contribution of our study is twofold. The biggest novelty of our study is to identify the determinants of the intention of acceptance of VietGAP in Vietnam and in particular Quangnam and Danang. The determinants of the intention of adoption of VietGAP stem from

motivational, psychological, and perceptive factors. All conclusions are withdrawn from the qualitative and quantitative methods, hence the second novelty of our study lies in the combination of the qualitative and quantitative methods. Many new determinants of the intention of VietGAP application will be discovered from the quantitative method. The quantitative method is employed to verify the determinants of the adoption of VietGAP in the context of Vietnam.

For these purposes the paper proceeds as follows: section 2 presents a brief review of the literature and empirical evidence; section 3 discusses methodologies; section 4 contains the results and discussion; and section 5 draws policy implications and the conclusion.

2. LITERATURE REVIEW

Earlier theoretical frameworks and existing empirical evidence on the application of technological innovations to the agricultural sector are considered in the following three approaches:

The analysis based on [Bernoulli's \(1954\)](#) expected utility theory (EUT) documents that comparing innovative and traditional technology is immensely necessary for farmers to choose better innovative technology. The selection of technology depends on expecting utilities. Although a high consensus is documented in the empirical literature, there are still many unresolved issues. For example, [Batz et al. \(1999\)](#) report that the intention to ask for new technology is influenced by the complexity of the techniques and related risk. However, the empirical evidence on the decision of innovative improvement of producers based on the EUT theory is only influenced by the perception of maximizing expected benefits without considering the role of psychosocial factors as well as social pressure on farmers when deciding to apply the innovations. The analysis is based mainly on the theory of reasoned action (TRA), the theory of planned behavior (TPB), and the innovation diffusion theory (IDT). [Läpple and Kelley \(2013\)](#); [Wauters and Mathijs \(2013\)](#); [Bijttebier et al. \(2014\)](#); and [Terano et al. \(2015\)](#) reveal that farmers' decision making is driven by social psychology. [Bergevoet et al. \(2004\)](#) indicate that economic factors are not sufficient to explain producers' complicated decisions which are often governed by both economic and other objectives.

The framework also shows that farmers aware of the environmental issues are more likely to apply organic farming practices. The significant impact of subjective norms is mentioned in their analysis as strong evidence of the existence of social barriers. Overall the TPB theory proves useful in explaining farmers' decisions by identifying key factors. However, earlier discussions on TPB do not consider the role of information gathering from friends, media, or extension workers. The diffusion theory has explored the important role of communication in explaining farmers' intention of technological innovations. [Gebremariam \(2001\)](#) points out that the frequency of interaction between farmers and extension workers positively influences the decision of applying new technologies by corn and wheat producers in Tigray and Ethiopia. Popular theories are applied in this framework to consider the application based on socio-economic factors without mentioning motives, values, attitudes, and to explain farmers' intentions. In order to solve this problem [Jackson et al. \(2006\)](#) combine three theories - IDT, TRA, and TPB to point out that motivation, values, and attitudes are key elements in the decision making process of farmers. However, the biggest limitation is too focused on motivation and value to explain the decision of applying improvements without the existence of risk perception. [Borges et al. \(2015\)](#) recently examined farmers' implementation of technological innovation by a combination of expectancy theory and social psychology. Beliefs, awareness of the innovative characteristics, intentions, attitudes, subjective standards, behavioral awareness, goals, objectives, background elements including the characteristics of farmers, households, farms, the context of the farming, and the process of receiving information are the important determinants of adoption of technological innovation in the model.

Factors indirectly influencing the acceptance of technological innovation are also documented. Therefore many studies focus on socio-economic characteristics such as education level, age, farm size, land ownership, and accessible credit to investigate the behavior of implementing technological innovation in the agricultural sector (Läpple and Kelley, 2013; Lynne *et al.*, 1995). A negligible effect of gender on the decision to adopt technological advances is documented in the application of hybrid maize technology in Ghana (Doss and Morris, 2000). The decisions to apply innovations in agriculture are due to the importance of education to increase accessibility to information. Those with good access to information adopt positive attitudes to applying innovations in agriculture. Fadare *et al.* (2014) indicate that farmers' education level has a positive impact on behavior to apply advanced maize production processes in Nigeria. Weir and Knight (2000) show that the impact of education is positive, but farmers educated in their families are less likely to receive and implement agricultural initiatives compared to formally trained farmers.

Ghadim and Pannell (1999) document that social and demographic characteristics such as age, experience, gender, and education influence decisions to apply innovations via subjective perceptions or farmers' attitudes. However, it can be expected to have an indirect effect on farmers' perceptions and beliefs.

Overall, although empirical evidence has shown the determinants of adoption of technological innovation in the agricultural sector, it has not considered whether factors such as risk perception of the brand and awareness of producers' health affected their decisions. We therefore attempt to fill this gap in the literature by studying whether factors such as risk perception of the brand and awareness of producers' health are the determinants of the intention of VietGAP adoption through in-depth interviews of farmers.

3. HYPOTHESES DEVELOPMENT AND METHODOLOGY

3.1. Hypotheses development

Based on the theoretical framework and the existing empirical findings on the application of technological innovation and the context of Vietnamese agricultural sector, six hypotheses will be tested in this study.

According to the diffusion theory of Rogers (2010), communication is an important determinant in explaining farmers' the intention of technological innovation implementation because of the vital role of communication in exchange for information. Makokha *et al.* (1999) relates to the diffusion theory in order to confirm that farmers' characteristics such as the participation of argument and training, exchanging at forums and the role of leaders play an unimportant role in farmers' acceptance of technological innovation. In the meanwhile, frequent interactions between farmers and extension officers have a positive contribution to the application of new technologies. For example, this effect is found by Gebremariam (2001) in the case of corn and wheat in Tigray, Ethiopia.

H1: Communication is positively associated with the intention of VietGAP implementation.

Bernoulli (1954) expected utility theory (EUT) indicates that farmers will compare innovative and traditional technique and will apply innovations if technologies' expected utility outweighs than that of traditional technologies. The existing empirical evidence has also applied the theory such as Sarker *et al.* (2009); Dill *et al.* (2015). In the case of VietGAP, certainly, the application of VietGAP obtains benefits such as the decrease of pests because of high quality seed, stable production, the increase of effectiveness because of the decreased cost of income and the high price of outcome.

H2: The awareness of benefits is positively related to the intention of VietGAP acceptance.

Bergevoet *et al.* (2004) document that farmers who have the realization of environment or attention to the environment intend to choose organic farming practices. Furthermore, Sarker *et al.* (2009) indicate that the recognition of the impacts of technologies provides customers with safe products and improves environmental concerns. In the context of Vietnam, Vietnam is an agricultural country, although the improvement of technologies in producing has updated continually in recent time, the agricultural system also causes negative effects on the environment such as overusing of pesticides, low quality seed, outdated machines. The market is overwhelmed by “dirty” vegetables that have negative contributions to the environment and consumers’ health. Moreover, VietGAP’s strict regulations on seed and pesticides, pests have positive contributions on the decrease of air pollution, leading to a stable ecological environment. Therefore, the application of technological innovations such as VietGAP is encouraged because of producing environmentally friendly vegetables without negative effects on the environment and both consumers’ and producers’ health.

H3: The awareness of the environment is positively correlated to the intention of VietGAP application.

Ghadim *et al.* (2005); Wubeneh and Sanders (2006) document that the awareness of technical, weather and pests risks is related to the acceptance of new technologies. Furthermore, the difference in outcome prices between VietGAP-certified vegetables and other vegetables on the market is not significant. However, persuading consumers to utilize VietGAP-certified vegetables is a tough task, although VietGAP vegetables in Quangnam and Danang are large brand names. In other words, VietGAP-certified vegetables are rarely accepted by consumers because they are afraid of paying a steep price for other vegetables camouflaged by VietGAP vegetables.

H4: The awareness of risks is negatively correlated to the intention of VietGAP application.

Subjective norms are a set of viewpoints on social norms that influence on selves when behavior is conducted or not. Fishbein and Ajzen (1975); Borges *et al.* (2014) document that subjective norm-related factors include family, friends, neighbors, suppliers, worker of suppliers, extension centers, local government. These important objectives operate as the channels of disseminating information. More especially, those who are closely related to farmers such as family members will create favorable conditions in order to apply the innovative natural fields of grass. In the meanwhile, Bergevoet *et al.* (2004) find that the significant impact of subjective norms is the strong evidence for the existence of social barriers. In agricultural locations such as Quangnam and Danang, farmers incline to modify their behavior based on their family members, friends, and relatives.

H5: The intention of VietGAP adoption is positively correlated to subjective norms.

The Planned Behavior theory reveals that not all behavior is driven by the control of intelligence. Behavior could last on different levels from total controllable to uncontrollable behavior. In fact, when farmers recognize resources and opportunities, they will incline to adopt VietGAP program.

H6: The behavior of VietGAP application is positively associated with the awareness of behavioral control.

3.2. Methodology and Data

3.2.1. Research model

Following Borges *et al.* (2015), we propose a specification for the determinants of the intention on applying VietGAP standards of farmers in the context of Vietnam, in which our expectation is that intentions, communication, risk awareness, environmental awareness, social influence or

subjective norms, behavioural controls have a direct influence. In the meanwhile, some background factors such as sex, experience and education are expected to influence indirectly the farmers' intention on applying technological innovation (Abadi and Pannell, 1999). Detailed concept and scale of the model are as follows:

Intention (QD) application indicates the intention to apply VietGAP in vegetable production of farmers in the next season. This scale has 05 questions and has been studied by Wauters *et al.* (2017); Borges *et al.* (2014).

Communication (GT) demonstrates the ability of farmers' active communication. The scale is indicated by the farmer's assessment of 3 questions which are used by Gebremariam (2001). The method is built on Roger's diffusion of innovation theory (1962), which is further confirmed by Ayinde *et al.* (2010); Dill *et al.* (2015).

Risk awareness (NTR) documents farmers' perception of risks when deciding on applying technology innovation. This scale is built on Sambodo (2007) which has been tested by scholars such as Ghadim *et al.* (2005); Wubeneh and Sanders (2006).

Environmental awareness (NTA) represents the farmers' perception of the impact of applying technology innovation in agriculture on the environmental issues. This scale has 02 questions developed by Sarker *et al.* (2009).

Subjective norms (DM) indicate the impact of important and close people such as family members, friends that can affect the decision making. This scale is investigated by Sambodo (2007); Borges *et al.* (2014). Behavioural control (KS) is employed to assess farmers' selves on how difficult or easy it is to perform this behaviour. The measurement was developed by Sambodo (2007); Borges *et al.* (2014).

Table 1: Scale of factors influencing the intention on technological innovation adoption

Factors	Symbol	Observation variables
communication	GT	GT1 I frequently obtain the information on agriculture through media
		GT2 I frequently exchange on VietGAP programme with extension officers
		GT3 I exchange on VietGAP with my friends (in coffee shops)
The awareness of benefits	NTL	NTL1 The implementation of VietGAP enhances income
		NTL2 The adoption of VietGAP standard helps obtaining higher outcomes
		NTL3 Overall, the application of VietGAP standard brings more benefits
The awareness of risk	NTR	NTR1 Traders take advantage the brand name of VietGAP to trade
		NTR2 The implementation of VietGAP is risky to decreasing of outcomes
		NTR3 The price of income is unstable
		NTR4 Bad weather is difficult to adopt VietGAP standard
The awareness of environment	NTA	NTA1 Producers' health will improved when applying VietGAP
		NTA2 The adoption of VietGAP generates safe products to customers
		NTA3 Environment will be improved by the acceptance of VietGAP standard
		NTA4 Overall, the improvement of environment is a contribution of the application of VietGAP

The awareness of supply and demand	NTC	NTC1	My VietGAP-certified products are enough to supply to market
		NTC2	Customers knew VietGAP-certified products
		NTC3	Customers used VietGAP-certified products
Subjective norm	DM	DM1	My spouses think that should adopt VietGAP in the future
		DM2	My parents think that should apply VietGAP in the future
		DM3	My children think that should implement VietGAP in the future
		DM4	Co-operative chairs think that I should adopt VietGAP programme in the future
		DM5	Extension workers think that should apply VietGAP standard in the future
		DM6	The head of village think that should implement VietGAP in the future
		DM7	The association of framers think that should adopt VietGAP standard in the future
		DM8	Almost all farmers will implement VietGAP program in the future
		DM9	Those who important to me suggest that I should adopt VietGAP standard in the future
Behavioral control	KS	KS1	If I adopt VietGAP program, I will be affordable to capital
		KS2	My land is enough to apply VietGAP standard
		KS3	I will follow other farmers' method if I implement VietGAP
		KS4	If I implement VietGAP program, Post-harvest preservation will be not problematic to me in the future
		KS5	The growth of VietGAP-certified products is more important than others
		KS6	if I implement VietGAP, infrastructure will be appropriate
		KS7	if I implement VietGAP standard, the full of experience will be enough
		KS8	if I implement VietGAP, my knowledge will be sufficient
		KS9	if I implement VietGAP standard, the cost of application will be not large
		KS10	The implementation of VietGAP program is not beyond my ability
Intention	QD	QD1	I will continue to implement Vietgap standard in the next time
		QD2	I will introduce VietGAP to others in the future
		QD3	I intend to adopt VietGAP standard in the future
		QD4	I plan to apply VietGAP program in the future
		QD5	I decided to adopt VietGAP standard in the future
		QD6	Overall, I am willing to support the application of VietGAP

Besides these scales employed above, we suspect that some other scales can be used as the determinants of the intention on VietGAP standard application to vegetable production in Quangnam and Danang that have not been studied in the past as follow:

The first measurement is a risk awareness concept. Traders take advantage of VietGAP brand name to trade. Although there is no official publication using this scale, the results from the in-depth interviews of households in Hungmy and Bautron villages are documented as follows:

“Almost all supermarkets have 3 sources of vegetables: Truongxuan vegetables, Dalat vegetables and Hungmy vegetables. When being checked the source, they only display my goods but only one-third goods are provided by farmers, consistent with VietGAP standard. They require many

things such as brand, package, then they pushed up my prices and they only buy little for the purpose of display when being checked”....[a 39-year-old woman, Hungmy village].

This scale is also consistent with Pavlou (2003) who classified risks into financial risk, seller risk, and privacy risk.

The second measure, the application of VietGAP standard is to improve the health of producers, is in environmental awareness concept. The scale is based on in-depth interviews from farmers: “My family is a traditional vegetable grower from my father until now in the traditional manner, but now with VietGAP standard, my family uses composted fertilizers and uses non-prohibited pesticides. Compared to the past, the number of fertilizers and pesticides also is used limitedly. In general, following the new production process, the farmers can obtain a great benefit. Besides reducing the number of insecticides, our health is less affected and productivity is increased [a 48-year-old man, Hungmy village]. The scale is also consistent with the findings of Batz *et al.* (1999) that farmers will compare innovative and traditional technique and will apply innovations if technologies’ expected utility outweighs than that of traditional technologies.

The third measure, there are enough supply sources on VietGAP vegetables to market. Consumers have known about VietGAP-certified products and have used these to apply VietGAP standard of the concept of cognitive metric. Although there is no official publication using this scale, the above scale is indicated in the results of in-depth interviews with farmers in La Huong and Bau Tron as follows: “Consumers know plenty of dirty vegetables but the media also rarely shows about VietGAP vegetables. While only farmers pay attention to finding ways of producing more safe vegetables. In my opinion, there are currently a few producers of VietGAP vegetables. Perhaps, in Quangnam, there are only 4 places of production” [a 44-year-old man, Hungmy village].

“They do not believe for private reasons because television programs demonstrate about careless production of spraying pesticides that they do not believe it is true. Do not think that cleaning vegetables are not injected anything? It is not true, because the spraying of pesticides must be isolated. More specifically, the spraying of pesticides is prior to a few days before harvesting. However, when they know about spraying drugs, they do not dare to eat” [a 44-year-old man, Hungmy village]. These scales are also consistent with the theory of supply-demand.

During the period of observation and interview, farmers reveal that the adoption of VietGAP standards in vegetable production did not take much time, money and the application of VietGAP was not difficult. Thus, after discussing, the scales are removed, namely, the risks involving a cost of time, money and technique.

The application of technology in agriculture has been studied in different countries but complexity level in the perceptions, attitudes and socio-economic conditions in other countries is also very different from Vietnam in general and Quangnam and Danang in particular. Therefore, the qualitative approach is appropriate for describing and understanding perceptions and decisions of farmers. Next, quantitative methods (SEM) are employed to test and measure factors influencing the decision on applying VietGAP standards in vegetable production of farmers in Quangnam and Danang.

3.2.2. Research methodologies

The intention of technological innovation adoption in the production of safe vegetables is difficult and complicated tasks. In the meanwhile, no study is conducted comprehensively in Vietnam in general and Quangnam and Danang in particular on the intention of VietGAP adoption. Furthermore, the existing empirical evidence indicates that the determinants of the intention of technological innovation application is different across locations as well as fields. Certainly, the

determinants of the intention of VietGAP adoption will be different from other locations as well as fields because of Vietnamese agriculture characteristics. Thus, each quantitative or qualitative method could not deal with all concerns comprehensively. More specifically, if we only use the qualitative method, we will not discover new determinants of the intention of VietGAP adoption. Otherwise, if we only take advantage of the quantitative method, new findings will not explain farmers' behaviour on VietGAP implementation. Therefore, the combination of the quantitative and qualitative method is necessarily employed to addresses research questions and to confirm hypotheses as well as to supply the new determinants of the intention of technological innovation adoption. More specifically, we take advantage of the qualitative method in order to consider whether recently explored factors such as the complexity of awareness, attitudes, and macro-economic conditions have impacted on the determinants of the intention of technological innovation acceptance with SEM estimation. In the meanwhile, the quantitative method is also employed with the purpose of investigating whether new determinants captured from in-deep interviews and observing such as farmers' awareness and final decisions are associated with the intention of VietGAP adoption in the context of Vietnam, supported by Nvivo.

3.2.3. Data collection

This paper chooses Danang and Quangnam to study because of two following reasons: (1) This research approaches from the psychological perspective of farmers affected by perceived benefits, environment and social norms. Although Danang and Quangnam were separated from Quangnam-Danang province from 01 January 1997, the farmers share the same background of culture, and thus, these two areas are homogeneous, especially in cultivation conditions, weather and custom. Additionally, both areas have the same policies for the support of VietGap. This has led to similar standards in agriculture. (2) Choosing two local areas can increase the size of the sample. This could use statistical functions for analytical testing, implication. In addition, this study uses a multi-group method to examine the differences between the two localities, such as gender and age, that can overcome some limitations.

In terms of the qualitative method, a set of primary data from in-deep interviews is employed. However, in order to capture the usefulness of in-deep interviews, we conduct observations with the purpose of understanding the context of survey locations. Interviewees are farmers who directly take part in vegetable production and offer novel contributions in accordance with VietGAP standard. When signs of convergence are existent, in-deep interviews are done. In other words, we only continue to interview when new information documents. Finally, our survey is collected from 11 main agricultural workers through in-depth interviews distributed in 4 main locations (Hung My: 4, Lang Chau Bac: 2, Bau Tron: 3 and La Huong: 2). Our database is collected 2 times from December, 2015 to February, 2016 and from April, 2016 to May, 2016 because of the time of main crops.

Similarly, regarding the quantitative approach, continuing with a set of primary data collected from farmers who directly take part in vegetable production and offer novel contributions in accordance with VietGAP standards in the period of time from July to September, 2016 through in-deep interviews, the main differences compared to the database for the qualitative method are that our initial sample is expanded up to 3201 interviewees and we extend survey locations into 6 including Hungmy, Langchau, Bautron, Lahuong, Yenne and Tuyloan because 6 villages provide the majority of VietGAP products. However, we only retain responses that meet requirements. These screening procedures result in a final sample of 294 observations.

¹ This study uses linear structural analysis method. The research model has 40 measurement variables, and follows the rule of 5 observations/measurement variables. Hence, the minimum sample size is 200 (40x5). In order to guarantee the size of the sample for the statistical analysis model, the study selects 320 observations.

4. RESULTS AND DISCUSSION

4.1. Estimated results

The proposed initial scale has 8 concepts with 40 observation variables. Preliminary results from Cronbach Alpha and exploratory factor analysis (EFA) document that the 7 observation variables NRT2, DM2, DM3, DM6, DM7, KS1, QD4 are excluded because of a total correlation <0.3, not distinguishable, factor loading <0.5. After two extracts there are only 32 variables and 6 groups with a total variance of 49.6% (approximately 50% that are acceptable). It means that 6 factors explain the 49.6% variation of our database - the stop point when extracting the coefficients Eigenvalue value >1. Factor loading is more than 0.5, so observation variables are important and research concepts are convergent. The coefficient of KMO is 0.896 (satisfactory >0.5) that demonstrates the suitability of the factor analysis. Bartlett's test is statistically significant (sig & lt; 0.05). The 3, 4, 5, 6 factors were retained (behavioural controls, subjective norms, decisions, communication), 3 observation variables (NTA1, NTA2, NTA3) are environmental perception, and 4 observation variables (NTL1, NTL2, NTL3, NTL4) belong to the cognitive-benefit factor combined into a new factor – an environmental-benefit factor (NTLA). 3 observation variables (NTR1, NTR3, NTR4) are risk-awareness factors combining with 3 variables (NTC1, NTC2, NTC3) belonging to the supply-demand perception factor which becomes a new element - risk recognition factor (NTRC). It means that environmental cognition and benefit cognition are two concepts. Likewise, risk and supply-demand perception can be an entity in reality.

Therefore, after evaluating the EFA scale, the hypotheses are adjusted as follows:

H1: there is a positive relationship between communication and households' behaviour on the adoption of VietGAP standard to vegetable production.

H2: farmers' intention on VietGAP technique implementation to vegetable production is driven positively by the awareness of benefits – environment.

H3: the perception of risk is negatively associated with farmer's behaviour on VietGAP standard application to vegetable production.

H4: behavioural norms is positively correlated to households' intention on VietGAP standard adoption to vegetable production.

H5: farmers' behaviour on VietGAP technique acceptance to vegetable production is positively related to behavioural control.

The remaining 6 concepts with 32 variables are further assessed by CFA. CFA results with Chi square/df=1.287; GFI=0.895; TLI=0.977; CFI=0.980; RMSEA=0.031 document that the scale model of decisive factors for VietGAP standard adoption is in accordance with market data. However, due to GFI <0.9, the model should be improved by hooking the rest. The second CFA results are that Chi square/df=1.219; GFI=0.901; TLI=0.983; CFI=0.984; RMSEA=0.027. That means a scale model of decisive factors for applying VietGAP standards in accordance with market data.

Table 2 reports risk perception, behavioural controls, environmental benefits, subjective norms, decisions, and communication meet requirements on confidence.

Table 2: Verification results of the scale

Observation Variables	Number of observation variables	Confidence			Value
		A	Pc	Pvc	
NTRC	6	0.913	0.916	0.645	Satisfactory
KS	6	0.909	0.911	0.632	
NTLA	7	0.909	0.910	0.592	

DM	5	0.919	0.919	0.696
QD	5	0.875	0.878	0.593
GT_	3	0.935	0.935	0.828

Source: author’s calculations

SEM results with Chisquare/df=1.219; GFI=0.901; TLI=0.983; CFI=0.984; RMSEA=0.027 indicate that the scale model of decisive factors for VietGAP standard adoption is in accordance with market data. However, the results of the estimation (normalized) relationship among the concepts were not statistically significant at 90% (see Table 3). Therefore, it is necessary to consider eliminating the DM concept.

Table 3: Results of the causal relationship between concepts

	ESTIMATE	S.E.	C.R.	P
QD <---KS	0.265	0.067	3.982	***
QD<---GT	0.255	0.063	4.067	***
QD<---NTRC	-0.399	0.087	-4.571	***
QD<---DM	0.066	0.049	1.343	.179
QD<---NTLA	0.114	0.052	2.182	.029

Source: Author’s calculations,

Note: *** p< 0.001

If DM variable is removed, the estimation results are with Chisquare/df=1.150; GFI=0.919; TLI=0.990; CFI=0.991; RMSEA=0.023, while the remaining concepts in the model are statistically significant at the 90% confidence level (P<0.05).

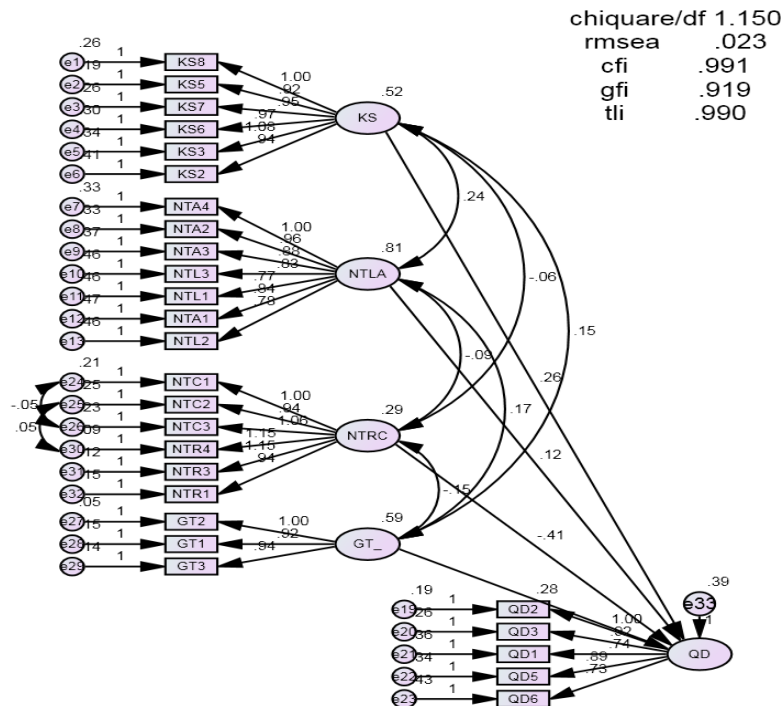

Figure 1: SEM results without DM

Source: author’s calculations

Table 4: Results of the causal relationship between concepts (DM excluded)

	ESTIMATE	S.E.	C.R.	P		ESTIMATE
QD	<---	KS	0.260	0.067	3.908	***
QD	<---	GT_	0.277	0.061	4.560	***
QD	<---	NTRC	-0.409	0.087	-4.690	***
QD	<---	NTLA	0.118	0.052	2.254	0.024

Source: author's calculations

Note: *** $p < 0.001$

Therefore, the concepts of behavioural controls, environmental benefits, and communication affect positively the farmers' intention on VietGAP standard adoption and are statistically significant ($p < 0.05$). Indeed, risk awareness has a negative impact on farmers' behaviour on VietGAP standard application and has statistical significance ($p < 0.05$). In other words, hypothesis H1, H2, H3, and H5 are accepted.

4.2. Discussion

Hypothesis H1 states that the communication factor is positively associated with households' behaviour on VietGAP standard application to vegetable production. As expected, the results point out that $\beta = 0.277$ and $p < 0.05$ and the more farmers communicate with their friends, neighbours, and officials in charge of agriculture or watch TV, the more likely they adopt VietGAP standard in vegetable production. The result is consistent with [Gebremariam \(2001\)](#); and [Makokha et al. \(1999\)](#). Qualitative findings also suggest that information exchanges from extension workers are poor, while farmers mainly exchange information with their friends and grasp information from the audio-visual media. Perhaps this is not the specific characteristic of Quangnam or Danang, but it is the general prevalence in Vietnam, where extension forces are insufficient to contact farmers frequently. Qualitative research shows that the behaviour on VietGAP standard adoption is not driven by the accessibility of information via internet, because the majority of interviewees are aged 40-55, so access to the internet is scant, and they only set up the internet with the main purpose of their children's online learning. Consequently the scale of communication is consistently removed. However, [Dill et al. \(2015\)](#) argue that frequently accessing the internet is significant to the intention of applying innovations. Therefore the implication drawn is that this scale should be used for areas of higher education.

Hypothesis H2 reveals that the awareness of benefits-environment is positively related to the intention of VietGAP standard implementation of planting vegetables. The results of $\beta = 0.118$ and $p < 0.05$ indicate that the more farmers realize the benefit, the more they decide to apply the VietGAP standard. We obtain the same conclusion from [Sarker et al. \(2009\)](#) who document that farmers aware of the application of agricultural improvement will improve their income. Farmers with environmental awareness who pay attention to the environment tend to apply clean farming methods ([Läpple and Kelley, 2013](#)). This result is consistent with the fact that farmers will compare innovative technology to traditional one and apply innovative technology if its expected utility is higher than the expected utility of traditional technology ([Batz et al., 1999](#)). The opinion that the more aware farmers are of health, the more they decide to apply VietGAP standard to the next crop is documented. In this context farmers' utility would increase if pesticides followed the international standard. In reality, use of high standard pesticides is not the main difficulty since farmers are aware that it would help to lower their health risks. This is also consistent with the findings of [Tran and Le \(2016\)](#) that the VietGAP program reduced health problems caused by exposure to pesticides.

Hypothesis H3 reports that the relationship between risk perception and behaviour on VietGAP standard adoption to vegetable production is inverse. The estimation results with $\beta = -0.409$ and $p < 0.05$ document that the more farmers are afraid of risk when applying the VietGAP technique, the

less they decide to apply VietGAP in vegetable production. We reached the same conclusion as Wubeneh and Sanders (2006); and Ghadim *et al.* (2005) that the risks of weather, pests, and price can negatively affect this intention. This also shows that farmers can recognize brand-related risks as the main reason for not applying the VietGAP standard.

The H4 hypothesis is not statistically significant in this framework. It is inconsistent with Borges *et al.* (2014); Wauters *et al.* (2017); and Wauters and Mathijs (2013) who document whether the intention to continue applying improvements of farmers is affected by reputable people. It can be observed that the voice of prestigious people is too blurry. The chairmen of co-operatives do not play a role in supplying outcomes, and also cannot bring advanced technologies to farmers. The village heads have only administrative roles, not roles in suggesting or orienting production.

Hypothesis H5 states that behavioural control is associated with the intention to adopt the VietGAP standard in vegetable production. $\beta = 0.260$ and $p < 0.05$ indicate that behavioural control is consistent with what we expect in the case of the intention of VietGAP standards to vegetable production in the context of Vietnam. When the farmers feel more confident to adopt the VietGAP process based on the success of other farmers, they tend to implement the VietGAP standard to vegetable production. We reach the same conclusion as did Laple and Kelley (2013); and Wauters *et al.* (2010).

5. CONCLUSION

Our main purpose was to identify the determinants of the behavior of adopting the VietGAP standards in vegetable production in Quangnam and Danang through a combination of the qualitative method (observation, in-depth interview) and quantitative method (SEM). The results show that there are 4 factors that influence farmers' intention to apply the VietGAP standards to vegetable production - communication, awareness of benefits and environment, risk awareness, and behavioral control. Subjective norms are not statistically significant in our model. A new finding is that farmers' perception risk of brand prevents the intention of applying the VietGAP standards in vegetable production.

Enhancing awareness of VietGAP among vegetable producers leads to increases in the supply of safe products and improvements in producers' health and the environment. Therefore farmers should actively update the VietGAP process and the benefits of applying the process to vegetable production. It is necessary to strictly follow the process of producing vegetables under VietGAP standards from seed selection to land preparation so that consumers trust products. Households need to build trust to link the production in order to ensure supply to the market. An important implication is that the perception of brand risk has reduced the intention of applying VietGAP standards in vegetable production of farmers. Therefore in order to avoid the abuse of brand name, farmers should learn about partnerships comprehensively in the signing of contracts and actively update the market information about the suppliers in order to have an appropriate plan.

Funding: This study received no specific financial support.

Competing Interests: The authors declared that they have no conflict of interests.

Contributors/Acknowledgement: All authors participated equally in designing and estimation of current research.

Views and opinions expressed in this study are the views and opinions of the authors, Asian Journal of Agriculture and Rural Development shall not be responsible or answerable for any loss, damage or liability etc. caused in relation to/arising out of the use of the content.

References

- Abadi, G. A. K., & Pannell, D. J. (1999). A conceptual framework of adoption of an agricultural innovation. *Agricultural Economics*, 21(2), 145-154. DOI: 10.1016/s0169-5150(99)00023-7
- Ajzen, I. (1991). The theory of planned behavior. *Organizational Behavior and Human Decision Processes*, 50(2), 179-211.
- Ayinde, O., Adewumi, M., Olatunji, G., & Babalola, O. (2010). Determinants of adoption of downy mildew resistant maize by small-scale farmers in Kwara State, Nigeria. *Global Journal of Science Frontier Research*, 10(1), 32-35.
- Batz, F. J., Peters, K., & Janssen, W. (1999). The influence of technology characteristics on the rate and speed of adoption. *Agricultural Economics*, 21(2), 121-130. DOI: 10.1016/s0169-5150(99)00026-2.
- Bergevoet, R. H., Ondersteijn, C., Saatkamp, H., Van Woerkum, C., & Huirne, R. (2004). Entrepreneurial behaviour of Dutch dairy farmers under a milk quota system: goals, objectives and attitudes. *Agricultural Systems*, 80(1), 1-21. DOI:10.1016/j.agsy.2003.05.001
- Bernoulli, D. (1954). Exposition of a new theory on the measurement of risk. *Econometrica*, 22(1), 23-36. DOI: 10.2307/1909829.
- Bijttebier, J., Ruyschaert, G., Marchand, F., Hijbeek, R., Pronk, A., Schlatter, N., Bechini, L. (2014). *Assessing farmers' intention to adopt soil conservation practices across Europe*. Paper presented at the Proceedings of 11th European IFSA Symposium.
- Borges, J. A. R., Foletto, L., & Xavier, V. T. (2015). An interdisciplinary framework to study farmers decisions on adoption of innovation: Insights from Expected Utility Theory and Theory of Planned Behavior. *African Journal of Agricultural Research*, 10(29), 2814-2825. DOI: 10.5897/ajar2015.9650.
- Borges, J. A. R., Lansink, A. G. O., Ribeiro, C. M., & Lutke, V. (2014). Understanding farmers' intention to adopt improved natural grassland using the theory of planned behavior. *Livestock Science*, 169, 163-174.
- Dill, M. D., Emvalomatis, G., Saatkamp, H., Rossi, J. A., Pereira, G. R., & Barcellos, J. O. J. (2015). Factors affecting adoption of economic management practices in beef cattle production in Rio Grande do Sul state, Brazil. *Journal of Rural Studies*, 42, 21-28.
- Doss, C. R., & Morris, M. L. (2000). How does gender affect the adoption of agricultural innovations? The case of improved maize technology in Ghana. *Agricultural Economics*, 25(1), 27-39.
- Fadare, O. A., Akerele, D., & Toritseju, B. (2014). Factors influencing adoption decisions of maize farmers in Nigeria. *International Journal of Food and Agricultural Economics*, 2(3), 45-54.
- Fishbein, M., & Ajzen, I. (1975). *Belief, attitude, intention and behavior: An introduction to theory and research*. Available at : https://www.researchgate.net/publication/233897090_Belief_attitude_intention_and_behavior_An_introduction_to_theory_and_research.
- Gebremariam, K. (2001). *Factors influencing the adoption of new wheat and maize varieties in Tigray, Ethiopia: The Case of Hawzien Woreda*. Unpublished M. Sc. Thesis, Alemaya University, Alemaya.
- Ghadim, A. K. A., Pannell, D. J., & Burton, M. P. (2005). Risk, uncertainty, and learning in adoption of a crop innovation. *Agricultural Economics*, 33(1), 1-9.
- Hoang, H. G. (2018). *Farmers' responses to VietGAP: a case study of a policy mechanism for transforming the traditional agri-food system in Vietnam: a dissertation presented in partial fulfilment of the requirements for the degree of Doctor of Philosophy in Agricultural Systems and Environment at Massey University, Palmerston North, New Zealand*. Massey University.
- Jackson, E. L., Quaddus, M., Islam, N., & Stanton, J. (2006). Hybrid Vigour of Behavioural Theories in the Agribusiness Research Domain. is It Possible? *Journal of International Farm Management*, 3(3), 25-39.

- Läpple, D., & Kelley, H. (2013). Understanding the uptake of organic farming: Accounting for heterogeneities among Irish farmers. *Ecological Economics*, 88, 11-19.
- Lynne, G. D., Franklin Casey, C., Hodges, A., & Rahmani, M. (1995). Conservation technology adoption decisions and the theory of planned behavior. *Journal of Economic Psychology*, 16(4), 581-598.
- Makokha, M., Odera, H., Maritim, H., Okalebo, J., & Iruria, D. (1999). Farmers' perceptions and adoption of soil management technologies in western Kenya. *African Crop Science Journal*, 7(4), 549-558.
- Mensah, O. S., Jincai, Z., Isaac, A. B., & Patrick, A. (2017). The role of institutional policies in promoting agribusiness development in rural China. *Agriculture and Food Sciences Research*, 4(2), 37-44.
- Pannell, D. J., Marshall, G. R., Barr, N., Curtis, A., Vanclay, F., & Wilkinson, R. (2006). Understanding and promoting adoption of conservation practices by rural landholders. *Australian Journal of Experimental Agriculture*, 46(11), 1407-1424.
- Pavlou, P. A. (2003). Consumer Acceptance of Electronic Commerce: Integrating Trust and Risk with the Technology Acceptance Model. *Int. J. Electron. Commerce*, 7(3), 101-134.
- Rogers, E. M. (1962). Diffusion of innovations. New York, USA. *Free Press of Glencoe*, 1, 79-134.
- Rogers, E. M. (2010). *Diffusion of innovations*. Fourth Edition. Simon and Schuster Inc. NY, USA.
- Sambodo, L. A. (2007). *The decision making processes of Semi-commercial farmers: a case study of technology adoption in Indonesia*, Doctoral dissertation, Lincoln University.
- Sarker, M. A., Itohara, Y., & Hoque, M. (2009). Determinants of adoption decisions: The case of organic farming (OF) in Bangladesh. *Extension Farming Systems Journal*, 5(2), 39-46.
- Terano, R., Mohamed, Z., Shamsudin, M. N., & Latif, I. A. (2015). Factors influencing intention to adopt sustainable agriculture practices among paddy farmers in Kada, Malaysia. *Asian Journal of Agricultural Research*, 9(5), 268-275.
- Tran, H. B. C., & Le T. Q. A. (2016). *Impact of VietGAP vegetable production on the health of farmers in Thua Thien hue province, Vietnam*. Economy and Environment Program for Southeast Asia (EEPSEA). Available at: http://www.eepsea.net/pub/rr/2015-RR19_BaoChau.pdf.
- Vu, T. H., Nguyen, M. D., & Santi, S. (2016). Litchi farmers' preference for the adoption of Vietnamese good agricultural practices in Luc Ngan district, Vietnam. *Journal of ISSAAS International Society for Southeast Asian Agricultural Sciences*, 22(1), 64-76.
- Wauters, E., & Mathijs, E. (2013). An investigation into the socio-psychological determinants of farmers' conservation decisions: method and implications for policy, extension and research. *The Journal of Agricultural Education and Extension*, 19(1), 53-72. DOI: 10.1080/1389224x.2012.714711.
- Wauters, E., Biolders, C., Poesen, J., Govers, G., & Mathijs, E. (2010). Adoption of soil conservation practices in Belgium: an examination of the theory of planned behaviour in the agri-environmental domain. *Land use Policy*, 27(1), 86-94. DOI: 10.1016/j.landusepol.2009.02.009.
- Wauters, E., D'Haene, K., & Lauwers, L. (2017). The social psychology of biodiversity conservation in agriculture. *Journal of Environmental Planning and Management*, 60(8), 1464-1484. DOI: 10.1080/09640568.2016.1231666.
- Weir, S., & Knight, J. (2000). *Adoption and diffusion of agricultural innovations in Ethiopia: the role of education*. CSAE Working Paper Series 2000-05, University of oxford, institute of economics and statistics, centre for the study of African economies.
- Wubeneh, N. G., & Sanders, J. (2006). Farm-level adoption of sorghum technologies in Tigray, Ethiopia. *Agricultural Systems*, 91(1-2), 122-134. DOI: 10.1016/j.agsy.2006.02.002.